

# HEKLA SERIES

## Control panels and signalling equipment



Addressee for this information:  User |  Installer

### 1 DECLARATION OF CONFORMITY AND PERFORMANCE



no. 1328 – CPR – 0815

Standards: EN 54-2:1997/AC:1999/A1:2006  
EN 54-4:1997/AC:1999/A1:2002/A2:2006

### 2 LINKS



Scan a QR code to reach the page of the related product on the [www.elmospa.com](http://www.elmospa.com) website.

An easy registration is required.

Software and all the technical documentation are available on product page.



HEKLA  
[bit.ly/2V11UsF](http://bit.ly/2V11UsF)



HLNODE  
[bit.ly/3dQ013y](http://bit.ly/3dQ013y)



HLREPEATER  
[bit.ly/3eYbK18](http://bit.ly/3eYbK18)

### 3 DESCRIPTION



HEKLA is a series of analogue addressable control panels and repeater panels that can be connected together by means of a RS-422 serial line, acting like a single control panel.

The HEKLA control panel includes a frontal panel for controlling the system.

The HLNODE control panel does not have its own front panel for control and must be connected to at least one HEKLA control panel.

#### Main network features

- 32 nodes (control or repeater panels), max. 31 of which are control panels
- 384 fully programmable zones
- 512 groups of programmable alarm warning devices
- 512 groups of programmable I/Os
- Historic log (10000 entries)
- Older events automatically deleted to make room for new ones
- Configuration by means of front keypad and software for PC

#### Main features of HEKLA and HLREPEATER

- Backlit 240×64 px graphic LCD display
- Multilingual support (select language via menu)
- Built-in 16-zone fire zone LED indicator

#### Main control unit features

- Compatible with all FYRA devices
- Between 1 and 4 loops per control panel
- Up to 250 addresses per loop (with 1 or 2 loops)
- Up to 125 addresses per loop (with 2 or 4 loops)

- Up to 32 individually programmable alarm warning devices per loop (addresses 94–125)
- 2 conventional individually programmable alarm warning devices
- 2 fire output relays (C/NC/NO)
- 1 fault relay (NC - opens in the event of a fault)

## Motherboard

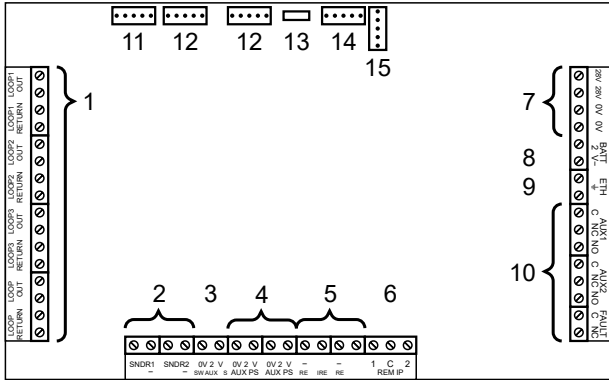

- 1 Loop
- 2 Conventional sounder supervised outputs
- 3 Resettable auxiliary power supply output
- 4 Auxiliary power supply outputs
- 5 Supervised outputs for alarm or fault signal transmission
- 6 Remote commands
- 7 Power input
- 8 Batteries
- 9 Earth
- 10 Relay outputs (unsupervised)
- 11 Front display card connector HEKLA
- 12 RS-422 network card connectors
- 13 USB micro-B connector for programming
- 14 Connectors for HLLANGPRO
- 15 Connector for front LEDs HLNODE

The user manual and this quick guide are supplied with the control unit.

This quick guide gives a summary of the mounting and initial setup procedure for the HEKLA system.

For complete and detailed information, please see technical and programming manuals available on [www.elmospa.com](http://www.elmospa.com) website.

## 4 INSTALLING THE CONTROL PANELS

 Please see control unit technical manual for detailed information.

### 4.1 Preparation

#### Cables

Use flame-retardant low smoke zero halogen twisted and shielded cables that are fire resistant for at least 30 minutes and meet current regulations.

- lay out the cables you will need for the project

These cables include:

- the loops
- the RS-422 network for connecting a number of control and repeater panels together
- the output lines
- any other inputs or outputs
- the control panels' mains power
- power supply for repeater panels, supplied by a control panel's power supply outputs

### Feeding cables into the control panel

 Make sure power source is disconnected.

The mains power cable must go through a different hole to that used by the system's other cables

Where possible, use the rectangular slot on the bottom of the control panel enclosure.

There are other cable entries available on the top.

- remove the covers to open up the required holes
- run the cables in conduits made from a material with UL94-HB or better flammability rating.
- use conduit-enclosure connection fittings with UL94-HB or better flammability rating.

### Feeding cables into the repeater panels

– punch out the required knockout holes in the enclosure  
The knockout holes consist in a rectangular slot on the bottom of the enclosure, and round holes in its top.

The instructions mentioned above for the control panel's conduits and fittings also apply here.

### Loop devices

The control panels are designed to handle the following options:

- 1 loop with 250 addresses (HL2LOOP card)
- 2 loops with 125 addresses each (HL2LOOP card)
- 2 loops with 250 addresses each (HL4LOOP card)
- 4 loops with 125 addresses each (HL4LOOP card)

In each loop:

- the total demand of the devices powered by the loop must not exceed 1 A
- each address must be used by just one device

### Notes

Some devices occupy more than one address.

**Example:** the MD4IO module occupies 8 addresses; if it is assigned address 3, then the next 7 addresses are taken as occupied, namely up to and including 10. These addresses must not be used for other devices.

Addresses are available between 1 and 125 and, on loops with 250 addresses, between 129 and 253.

**Important:** on the display and on the configuration software, addresses from 129 to 253 are shown as

if they were addresses 1 to 125 of the next loop.

Address set	Address shown	Address set	Address shown	Address set	Address shown
129 L1	1 L2	171 L1	43 L2	213 L1	85 L2
130 L1	2 L2	172 L1	44 L2	214 L1	86 L2
131 L1	3 L2	173 L1	45 L2	215 L1	87 L2
132 L1	4 L2	174 L1	46 L2	216 L1	88 L2
133 L1	5 L2	175 L1	47 L2	217 L1	89 L2
134 L1	6 L2	176 L1	48 L2	218 L1	90 L2
135 L1	7 L2	177 L1	49 L2	219 L1	91 L2
136 L1	8 L2	178 L1	50 L2	220 L1	92 L2
137 L1	9 L2	179 L1	51 L2	221 L1	93 L2
138 L1	10 L2	180 L1	52 L2	222 L1	94 L2
139 L1	11 L2	181 L1	53 L2	223 L1	95 L2
140 L1	12 L2	182 L1	54 L2	224 L1	96 L2
141 L1	13 L2	183 L1	55 L2	225 L1	97 L2
142 L1	14 L2	184 L1	56 L2	226 L1	98 L2
143 L1	15 L2	185 L1	57 L2	227 L1	99 L2
144 L1	16 L2	186 L1	58 L2	228 L1	100 L2
145 L1	17 L2	187 L1	59 L2	229 L1	101 L2
146 L1	18 L2	188 L1	60 L2	230 L1	102 L2
147 L1	19 L2	189 L1	61 L2	231 L1	103 L2
148 L1	20 L2	190 L1	62 L2	232 L1	104 L2
149 L1	21 L2	191 L1	63 L2	233 L1	105 L2
150 L1	22 L2	192 L1	64 L2	234 L1	106 L2
151 L1	23 L2	193 L1	65 L2	235 L1	107 L2
152 L1	24 L2	194 L1	66 L2	236 L1	108 L2
153 L1	25 L2	195 L1	67 L2	237 L1	109 L2
154 L1	26 L2	196 L1	68 L2	238 L1	110 L2
155 L1	27 L2	197 L1	69 L2	239 L1	111 L2
156 L1	28 L2	198 L1	70 L2	240 L1	112 L2
157 L1	29 L2	199 L1	71 L2	241 L1	113 L2
158 L1	30 L2	200 L1	72 L2	242 L1	114 L2
159 L1	31 L2	201 L1	73 L2	243 L1	115 L2
160 L1	32 L2	202 L1	74 L2	244 L1	116 L2
161 L1	33 L2	203 L1	75 L2	245 L1	117 L2
162 L1	34 L2	204 L1	76 L2	246 L1	118 L2
163 L1	35 L2	205 L1	77 L2	247 L1	119 L2
164 L1	36 L2	206 L1	78 L2	248 L1	120 L2
165 L1	37 L2	207 L1	79 L2	249 L1	121 L2
166 L1	38 L2	208 L1	80 L2	250 L1	122 L2
167 L1	39 L2	209 L1	81 L2	251 L1	123 L2
168 L1	40 L2	210 L1	82 L2	252 L1	124 L2
169 L1	41 L2	211 L1	83 L2	253 L1	125 L2
170 L1	42 L2	212 L1	84 L2		

The table is also valid by replacing L1 and L2 with L3 and L4. Only output devices with addresses between 94 and 125 can be activated by a sounder group. The other output devices are not programmable.

See the individual device's technical manual for:

- information on the number of addresses it occupies
- the address selection procedure
- wiring instructions

## 4.2 Device mounting

- unscrew cover closing screws
- open the hinged door or remove the cover
- punch out the required cable entry holes

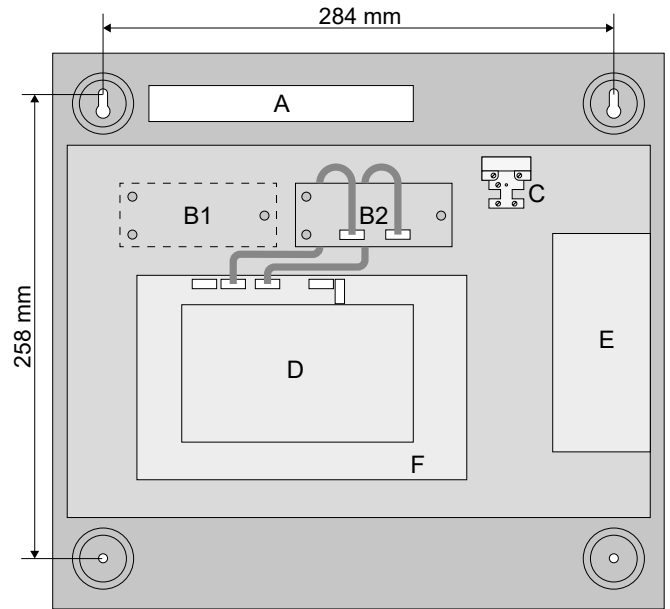

- A** Hole for cable passage
- B** Positions for communication cards
- C** Terminal block for mains power
- D** Position for loop card
- E** Power unit
- F** Dip switch selectors

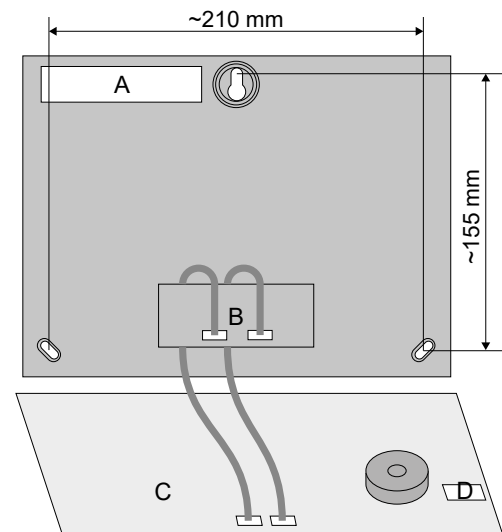

- A** Hole for cable passage
- B** Connection card
- C** Front panel card (pulled down)
- D** Power supply terminal block

- fix the control unit case to the wall using screws and dowels suitable for the type of wall (not included)

### Loop board

- plug the chosen loop card into the middle of the motherboard

**Note:** be careful to plug the connectors in without forcing them.

- fasten the card using the M4 screws provided

### Control/repeater panel networks

If the system comprises a number of control or repeater panels:

- install the communication card in the relevant slot
- connect the communication card as illustrated at the beginning of this chapter
- set the control panels' addresses, making sure you do not have any duplicates

Set the address by moving the first 5 DIP switches.

The switch is in the ON position if the switch is up, and vice versa OFF if it is down.

Addr.	dip ON	Addr.	dip ON	Addr.	dip ON
1	1 - - -	12	- - 3 4 -	23	1 2 3 - 5
2	- 2 - - -	13	1 - 3 4 -	24	- - - 4 5
3	1 2 - - -	14	- 2 3 4 -	25	1 - - 4 5
4	- - 3 - -	15	1 2 3 4 -	26	- 2 - 4 5
5	1 - 3 - -	16	- - - - 5	27	1 2 - 4 5
6	- 2 3 - -	17	1 - - - 5	28	- - 3 4 5
7	1 2 3 - -	18	- 2 - - 5	29	1 - 3 4 5
8	- - - 4 -	19	1 2 - - 5	30	- 2 3 4 5
9	1 - - 4 -	20	- - 3 - 5	31	1 2 3 4 5
10	- 2 - 4 -	21	1 - 3 - 5		
11	1 2 - 4 -	22	- 2 3 - 5		

Set the address of repeater panels after switching on, via the 8-5-1 menu.

## 4.3 Wirings

### Loop

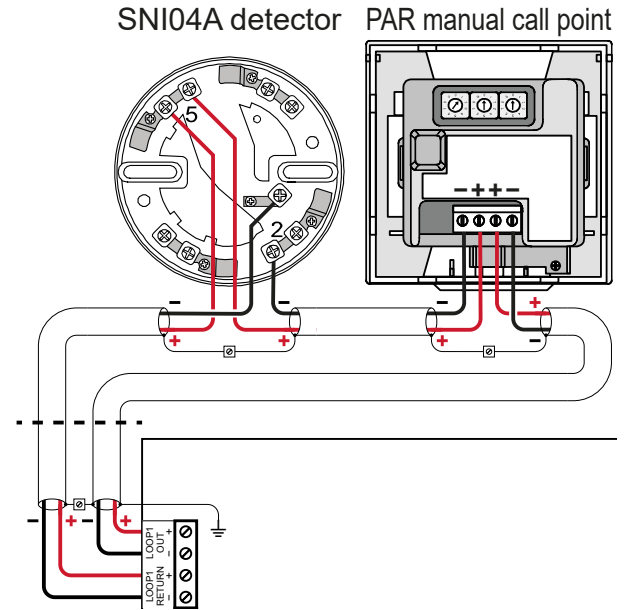

Example of loop 1 connection (with 2 devices connected)

- connect the two ends of each loop to the motherboard, as illustrated in the example

**Note:** the HL4LOOP card set to 2 loops uses the LOOP1 and LOOP3 terminals.

### Control and repeater panel network

The nodes (control and repeater panels) are arranged along the loop formed by the various lengths of RS-422 cable. The order of the nodes does not necessarily have to match the order of the addresses.

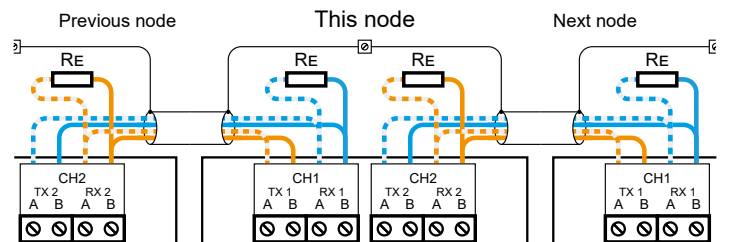

Re = 100 Ω end-of-line resistor

- choose a conventional direction for the cable so that you know, out of two devices in series, which is the previous one and which the next
- connect TX1 to RX2 on the previous device
- connect RX1 to TX2 on the previous device
- connect TX2 to RX1 on the next device
- connect RX2 to TX1 on the next device

**Note:** always connect A with A and B with B.

- connect the end-of-line resistors provided with the HLNETH board
- choose a single control panel in which to connect the shields on the cables to the motherboard's earth terminal

## Sounders (SNDR outputs)

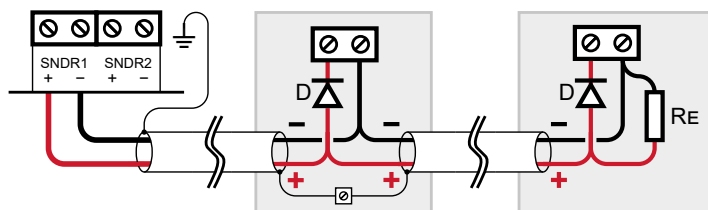

D = 1N4001 diode

Re = 10 kΩ end-of-line resistor

Use one of the supervised outputs marked SNDR as a general alarm output.

The general fault output is the NC relay with the FAULT silkprint.

### Connecting shielding to earth

- connect the shields on the cables installed thus far to the board's ETH terminals

**Note:** every cable must be connected to earth at a single point of the system, without creating loops; if the shield on a cable is already connected to earth - for example, c/o a power supply - it should not be connected to the control panel's earth.

### Device mounting

- fix to proper fixing points all the cables wired to the control unit board

### Mains power (control panel)

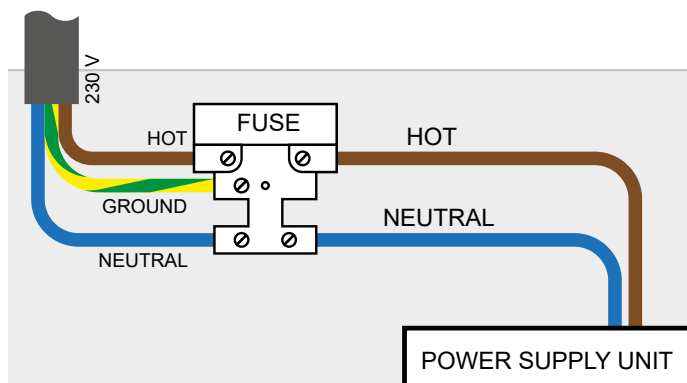

- connect the 230 V power cable to the three-way terminal block

## Power (repeater panel)

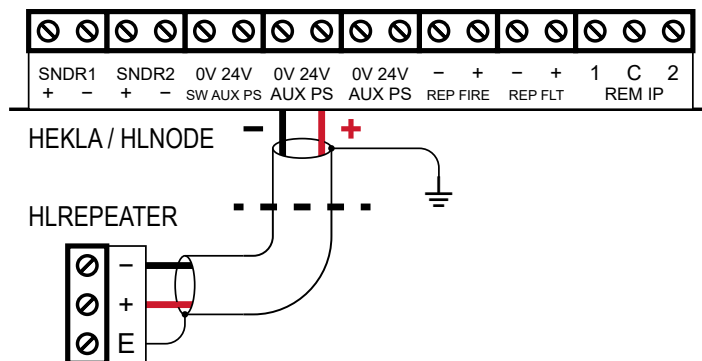

- connect the power supply terminals to an auxiliary output on one of the control panels

**Note:** do not use the output screen-printed with the wording SW AUX PS: this is an output that has its power cut off for 15 seconds at every reset, as a reset signal for sirens.

### 4.4 Power on

- clean the circuit boards thoroughly to remove any metal shavings
- make sure there are no stray wires
- power up all the devices connected to the loops
- power up all the control panels
- The System ON LED on the front panel flashes, indicating that the control panel is in installation mode
- press the button System Reset

### 4.5 Using the keypad menu

#### 4.5.1 Access to the keypad installer menu

- press **ENTER**
- enter the installer access code (default 

**Note:** if you fail to enter the code within 10 seconds, the control panel returns to the previous screen.

- press **ENTER**

#### 4.5.2 Menu and functions browsing

##### Menu

- press  and  to scroll through the menu options
- press **ENTER** to access a menu option

Some options in turn contain their own menu, while others contain functions.

- press **ESC** to exit a menu



The menus are numbered and are arranged in a tree structure.

For example, to go to **8-4-8 Set Installer Access Code:**



- keep pressing  until you get to **8 General**
- press **ENTER**
- keep pressing  until you get to **8-4 Other Features**
- press **ENTER**

- keep pressing  until you get to **8-4-8 Set Installer Access Code**
- press **ENTER**

## Functions

- press  and  to change the content of a field
- press  to move the cursor or change loop
- press **ENTER** to go to the next field and save
- press **ESC** to go back to the previous field
- press **ESC** while on the first field to exit the function

### 4.5.3 Change language

- enter the installer menu
- enter the menu **8-4-6 Select language**
- press  and  to select a language
- press **ENTER** to confirm

### 4.5.4 Active/installation mode



In **programming mode**, the control panel recognizes and saves each new device connected.

the **System ON** LED flashes.



In **active mode**, the control panel does not accept new devices and reports their appearance as an error.

the **System ON** LED is steadily lit.

To switch mode:

- enter the installer menu
- enter the menu **8-4-1 Active/Installation Mode**
- press **ENTER**
- press  and  to select the mode you want
- press **ENTER**

### 4.5.5 Setting repeater addresses

- enter the installer menu
  - enter the menu **8-5-1 Configure Panel Number**
  - press  and  to change address
- Choose a free network address.
- press **ENTER** to confirm

The system is reset following the change.

## 4.6 Setup

Control unit configuration operations will require the use of the keypad installer menu and the HLBROWSER software.

The two elements are complementary.

To add text, such as the name of devices, you will need to use HLBROWSER software.

### Guide to first configuration

The next paragraphs describe the most common configuration operations.

When installing for the first time, follow the steps in the order given and the control panel will be set up ready to handle the essential functions of the fire protection system.

The operations require the installer to access the keypad menu and use HLBROWSER software.

 *In any case, we recommend consulting the control unit programming manual and the manuals of the single devices for details on all the available configuration options.*

On initial power up, the control panel is in installation mode ("System ON" LED flashing) and automatically registers all the modules and devices connected:

- wait for the information to appear on the LCD display



### 4.6.1 Configuration software installation

- enter the installer menu
- view the current version (**8-9 Version Information** menu)
- make a note of the number in the lower right (e.g. VR010305)

Its first 4 digits match the HLBROWSER version to download (e.g. 1.03).

- login to the [www.elmospa.com](http://www.elmospa.com) website
- on the control panel page, download the correct HLBROWSER\_[version number].exe file
- extract the file from the folder
- open the file and follow the displayed instructions

### 4.6.2 Connecting to the configuration software

- connect the control panel's board to the PC using a USB 2.0 micro-B cable (not provided)
- enter the installer menu
- open HLBROWSER
- click the  icon to copy the control panel's configuration to HLBROWSER
- click the  icon to copy the list of automatically registered devices to HLBROWSER

### 4.6.3 Assign the devices to the zones

Once the configuration has been read

- go to **Devices** page
- from the drop-down menu at the top, select **Device**
- select the control panel, the loop and the device whose data you want to update
- set **Zone**

This procedure can be also be performed via the keypad.

- enter the installer menu
- go to **3-4 Assign Zone to Device** menu

Detailed instructions on the menu functions can be found in the programming manual.

### 4.6.4 Data writing

- enter the installer menu
- switch the control panel to installation mode (**8-4-1 Active/Installation Mode** menu)
- click the  icon to save the configuration on the control panel

The configuration is saved on a single control panel.

The other control panels report a sync failed error.

- propagate the configuration via the **8-5-4 Broadcast Configuration** menu on the control panel that has already been configured

## 4.7 System test

The purpose of the system test is to check that the system is working properly.

It must be carried out after any change to the programming, and at regular intervals

- enter the installer menu

**Note:** this procedure can also be performed by logging in as a user, as described in the user manual.

- go to the menu **7-2 Test Sounders**
- press **ENTER** to start a test step

 See user manual for detailed information.

- go to the menu **7-4 Test Zones**
- press **ENTER** to start a test step

 See user manual for detailed information.

- press **Lamp Test** and check that all LEDs on the control panel light up and that the display features alternating white and black lines
- check that all the front panels of each node are displaying the same information and have the same LEDs lit
- check that, when you access the **8-5-2 Known Panels** menu on each control or repeater panel, all connected devices are visible

## 4.8 Starting detection

- close control unit case
- switch the control panel to active mode (**8-4-1 Active/Installation Mode** menu)
- press the button **System Reset**

### If errors come up

- make a note of the errors that come up
- scroll down the list by pressing **Fault**
- switch the control panel to installer mode (**8-4-1 Active/Installation Mode** menu)
- solve the errors that come up, opening the enclosure where necessary
- repeat the detection start procedure

## 4.9 Batteries

We recommend installing the batteries once commissioning is complete.

That way, power can be cut off quickly if there are issues during the commissioning.

- make sure that the voltage at the battery connection terminals is  $27.5 \pm 0.5$  V
- place the batteries inside the enclosure

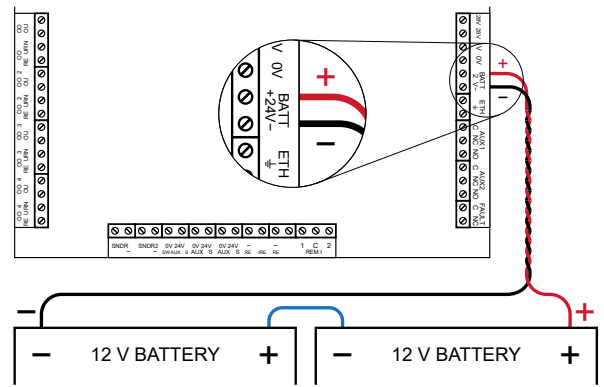

- remove the resistor initially connected to the BATT 24V terminals
- connect the BATT 24V terminals to the batteries, making sure you get polarity right

 Inverting polarity can damage the control panel irreparably

**Note:** for neater wiring, twist together the two wires going to the battery and route them as close as possible to the bottom edge of the enclosure.

### Power supply tests

- remove the wire between the two batteries temporarily. After a few seconds, the control panel should report a fault.
- reconnect the wire
- press the button **System Reset**
- disconnect the 230 V power on all power supplies. After a few seconds, the control panel should report the power supply fault
- restore power
- press the button **System Reset**
- make sure the control panel is in active mode (**System ON** LED steadily lit)

## EU DECLARATION OF CONFORMITY

The product complies with current European EMC and LVD directives.

The full text of the EU declaration of conformity is available at the following internet address: [www.elmospa.com](http://www.elmospa.com) – registration is quick and easy.



## GENERAL WARNINGS



This device has been designed, built and tested with the utmost care and attention, adopting test and inspection procedures in compliance with current legislation. Full compliance of the working specifications is only achieved in the event the device is used solely for its intended purpose, namely:

### Control panels and signalling equipment

The device is not intended for any use other than the above and hence its correct functioning in such cases cannot be assured. Consequently, any use of the manual in your possession for any purpose other than those for which it was compiled - namely for the purpose of explaining the product's technical features and operating procedures - is strictly prohibited.

Production processes are closely monitored in order to prevent faults and malfunctions. However, the components adopted are subject to an extremely modest percentage of faults, which is nonetheless the case with any electronic or mechanical product.

Given the intended use of this item (protection of property and people), we invite you to adapt the level of protection offered by the system to suit the actual situation of risk (allowing for the possibility of impaired system operation due to faults or other problems), while reminding you that there are specific standards for the design and production of systems intended for this kind of application.

**We hereby advise you (the system's operator) to see that the system receives regular routine maintenance, at least in accordance with the provisions of current legislation, and also check on as regular a basis as the risk involved requires that the system in question is operating properly, with particular reference to the control unit, sensors, sounders, dialler(s) and any other device connected. You must let the installer know how well the system seems to be operating, based on the results of periodic checks, without delay.**

Work involved in the design, installation and maintenance of systems incorporating this product should be performed only by personnel with suitable skills and knowledge required to work safely so as to prevent any accidents. It is vital that systems be installed in accordance with current legislation. The internal parts of certain equipment are connected to the mains and therefore there is a risk of electrocution when maintenance work is performed inside without first disconnecting the primary and emergency power supplies. Certain products include batteries, rechargeable or otherwise, as an emergency backup power supply. If connected incorrectly, they may cause damage to the product or property, and may endanger the operator (explosion and fire).

## INSTALLER WARNINGS



Comply strictly with current standards governing the installation of electrical systems and security systems, and with the manufacturer's directions given in the manuals supplied with the products.

Provide the user with full information on using the system installed and on its limitations, pointing out that there are different levels of security

performance that will need to suit the user's requirements within the constraints of the specific applicable standards. See that the user looks through the warnings given herein.

Work involved in the design, installation and maintenance of systems incorporating this product should be performed only by personnel with suitable skills and knowledge required to work safely so as to prevent any accidents. It is vital that systems be installed in accordance with current legislation. The internal parts of certain equipment are connected to the mains and therefore there is a risk of electrocution when maintenance work is performed inside without first disconnecting the primary and emergency power supplies. Certain products include batteries, rechargeable or otherwise, as an emergency backup power supply. If connected incorrectly, they may cause damage to the product or property, and may endanger the operator (explosion and fire).

## USER WARNINGS



Check the system's operation thoroughly at regular intervals, making sure the equipment can be armed and disarmed properly.

Make sure the system receives proper routine maintenance, employing the services of specialist personnel who meet the requirements prescribed by current regulations.

Ask your installer to check that the system suits changing operating conditions (e.g. changes in the extent of the areas to be protected, change in access methods, etc...)

## MAIN SAFETY RULES



The use of the device is forbidden for children and unassisted disabled individuals.

Do not touch the device when bare footed, or with wet body parts. Do not directly spray or throw water on the device.

Do not pull, remove or twist the electric cables protruding from the device even if the same is disconnected from the power source.

## DISPOSAL WARNINGS

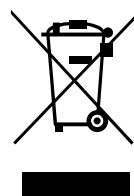

IT08020000001624

In accordance with Directive 2012/19/EU on waste electrical and electronic equipment (WEEE), please be advised that the EEE was placed on the market after 13 August 2005 and must be disposed of separately from normal household waste.

This product needs batteries for correct functioning. Exhausted batteries have to be delivered to dumping grounds authorised for battery collection. The materials used for this product are very harmful and polluting if dispersed in the environment.